



Quality Products. Service Excellence.

Mechanical Humidistat *SKH Series*



Features

- Mechanical Humidistat regulates the control of heaters or fans whenever the preset level of relative humidity.

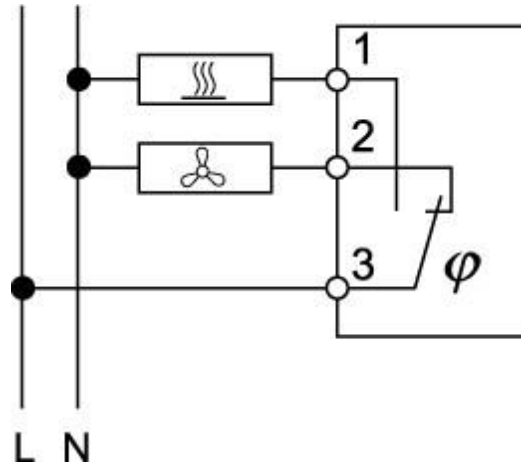

Part No.	Dimensions Height x Width x Depth	Switching Capacity
SKH600NCC	3.5 x 1.5 x 1.8	NOC FAN AC 120 V - 2A
		NOC FAN AC 240 V - 2A
		NCC Heater AC 120 V - 5A
		NCC Heater AC 240 V - 5A
		DC 30 Watts
Control Range:	40 to 90% r.H.	
Differential Gap:	Approximately 5%	
Switch Point Accuracy:	+/- 4% based on 50% r.H.	
Working Temperature Range:	30°F to 140°F (0°C to 60°C)	
Storage Temperature:	-5°F to 180°F (-20°C to 80°C)	
Type of Contact:	Change-over switch	
Sensor:	Polyamide band	
Type of Connection:	2-pole clamp, For AWG14 (2.5mm2)	
Color:	RAL 7035 - Grey	
Protection Category:	IP20	
Mounting:	Easily installed by clip mounting on 35mm DIN rail (7 included)	
Approval:	CE	

Data subject to change without notice